

CHAPTER 2: DECK LAMINATION

GELCOAT SPECIFICATIONS:

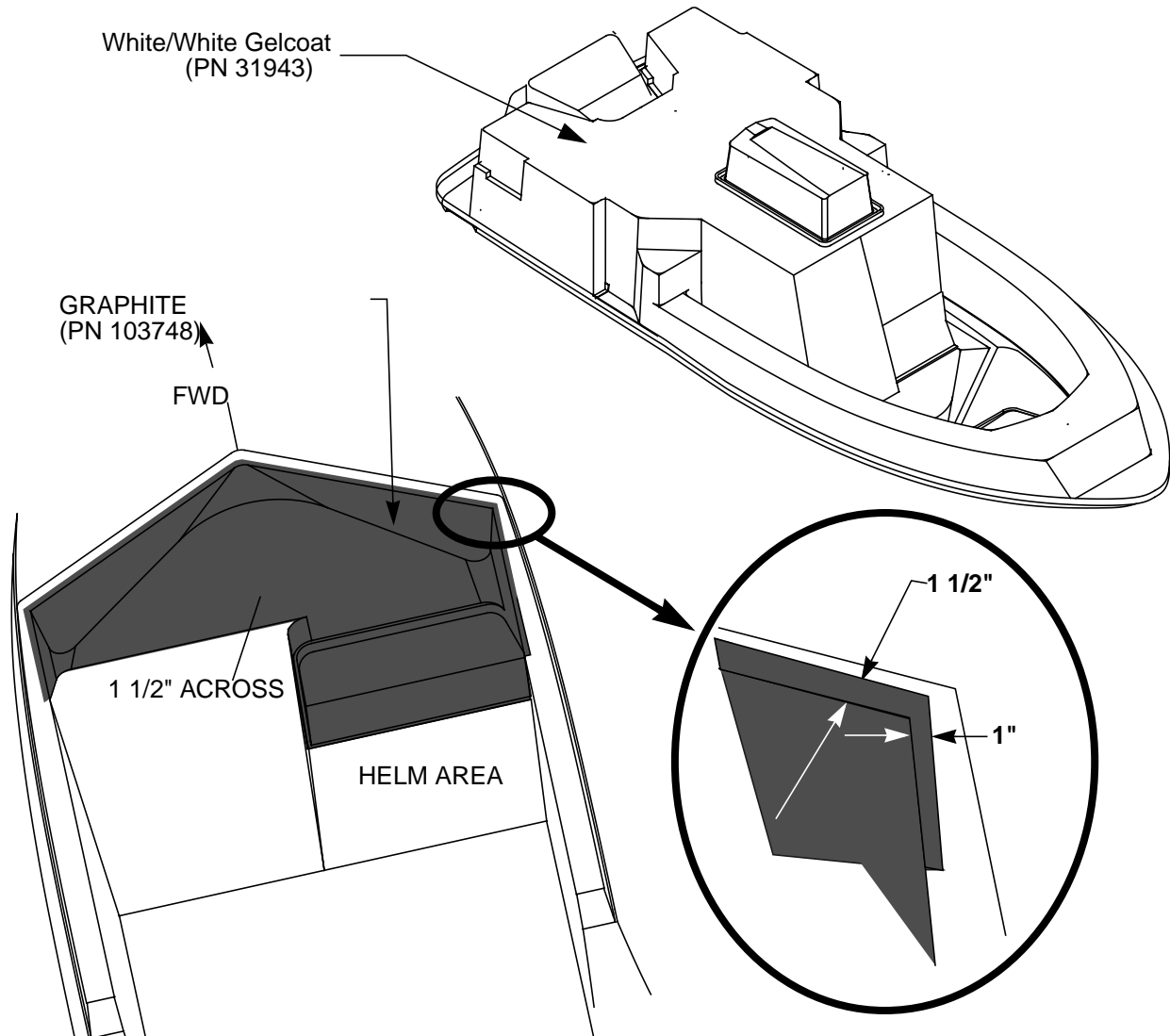

1. Apply 18-20 mils of Gelcoat to entire deck, 6-7 mils of per pass in three even coats.
2. Allow a minimum of 30 seconds between coats.

(PN 39853) Dream White Gelcoat 53 lbs
 (PN103748) Graphite 2.1 lbs

**MODEL: 1802FJ
DECK**

**ALL CHOP TO BE
ROLLED OUT
TIGHT AND AIR
FREE (NO DRY
AREAS)**

GELCOAT		QUANTITY	TOTAL WEIGHT
1	Spray Entire Part Except Dash (Dream White)	20 MILS CHOP	42.70
2	Spray Dash (Graphite)	20 MILS CHOP	2.10
3	Roll Out		
TOTAL			44.80

SKINCOAT		QUANTITY	SCALE WEIGHT
1	Chop Entire Part	60 MILS CHOP	21.53
2	Roll Out		
3	Promat Outside Radii and Sheer	NEMPC 1708	
4	Squeegee		
5	LET CURE		
TOTAL			21.53

STIFFENING PRO- CEDURE		QUANTITY	SCALE WEIGHT
1	Chop Entire Part	90 MILS CHOP	32.30
2	Roll Out		
3	Install Stiffening		
4	Let Cure		
5	Chop Entire Part	60 MILS CHOP	21.53
6	Roll Out		
TOTAL			53.83

Spray Foam (PN 39867) 29 lbs

DECK STRUCTURE:

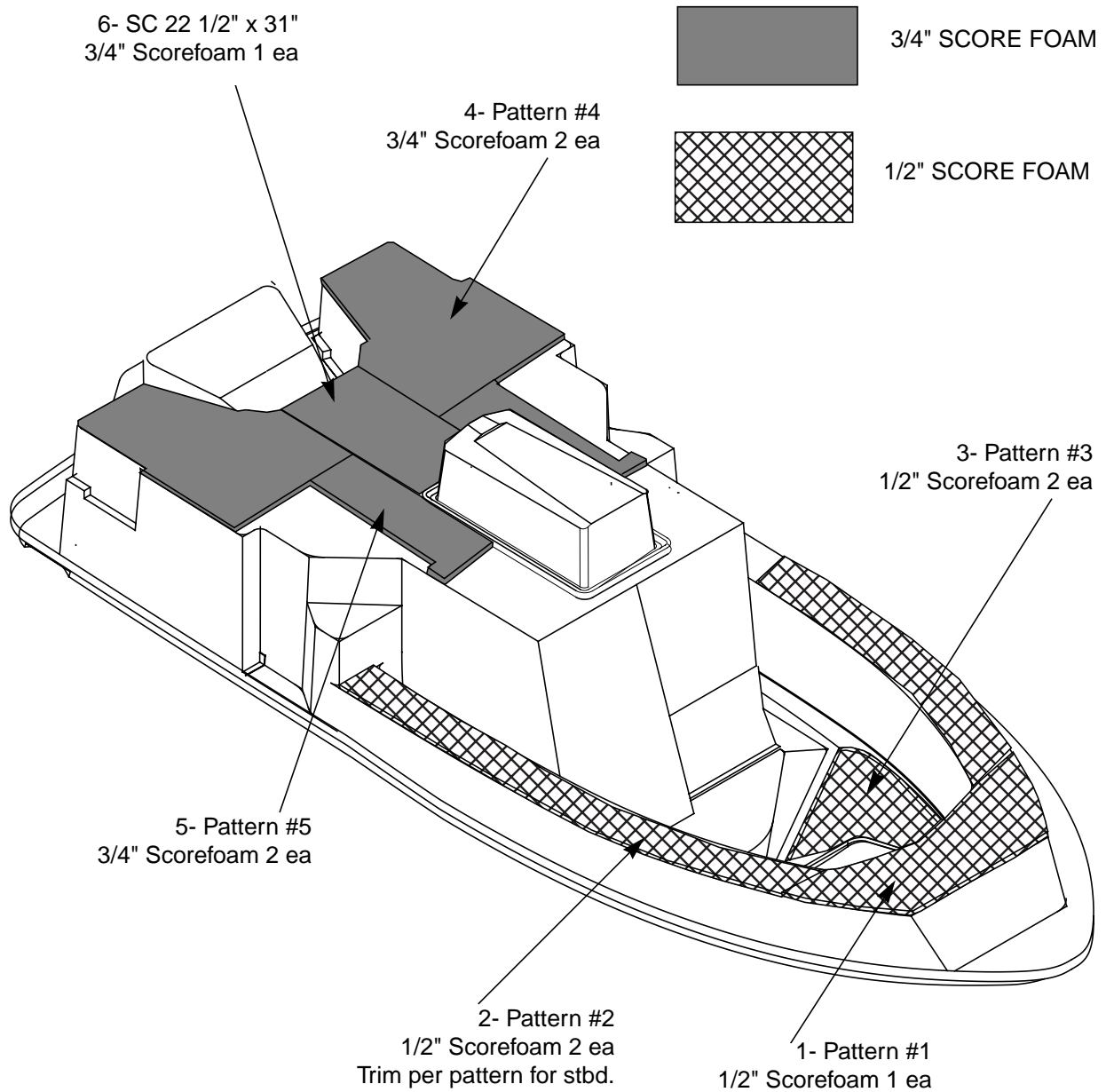

DECK STRUCTURE CONTINUED:

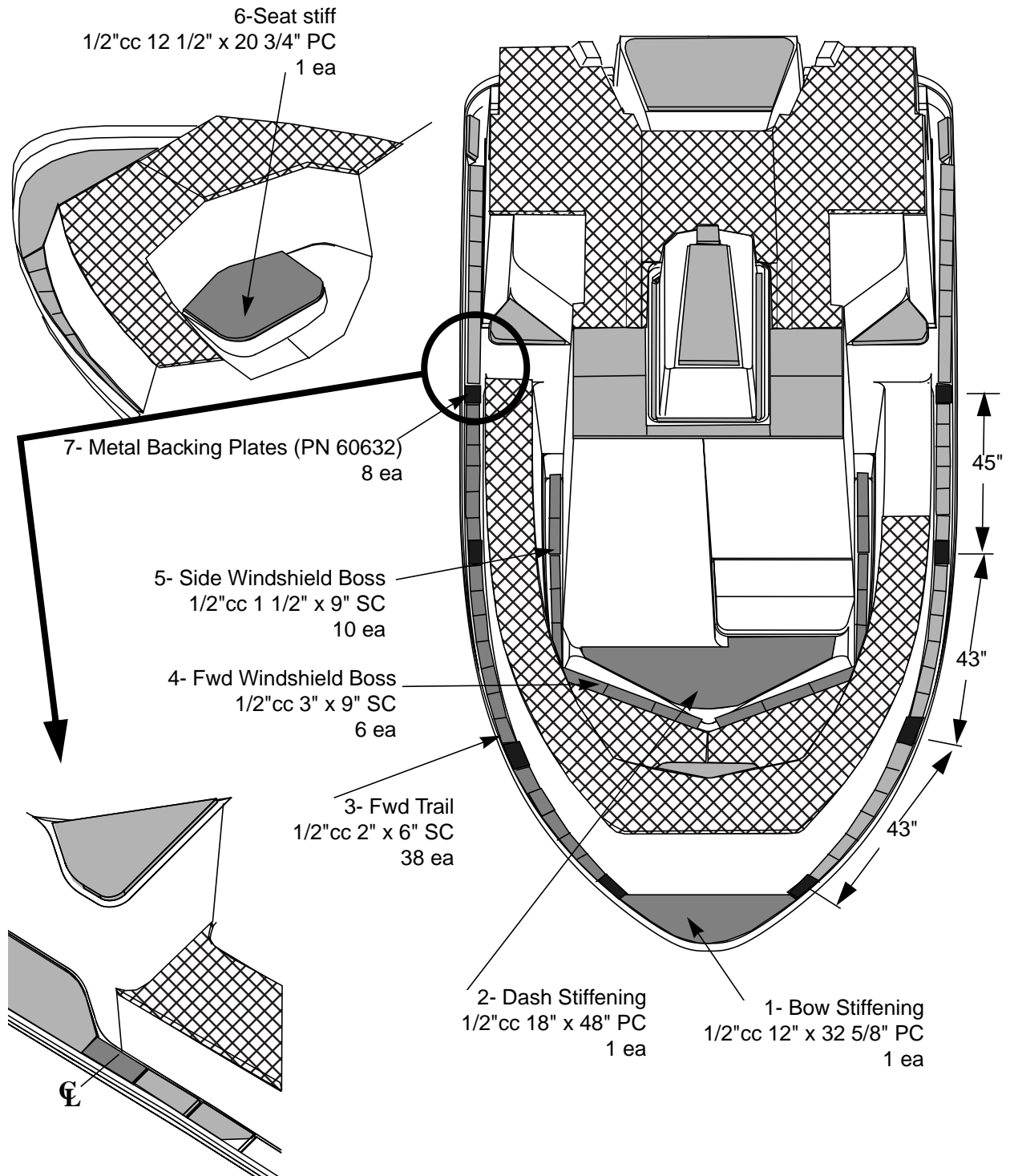

DECK STRUCTURE CONTINUED:

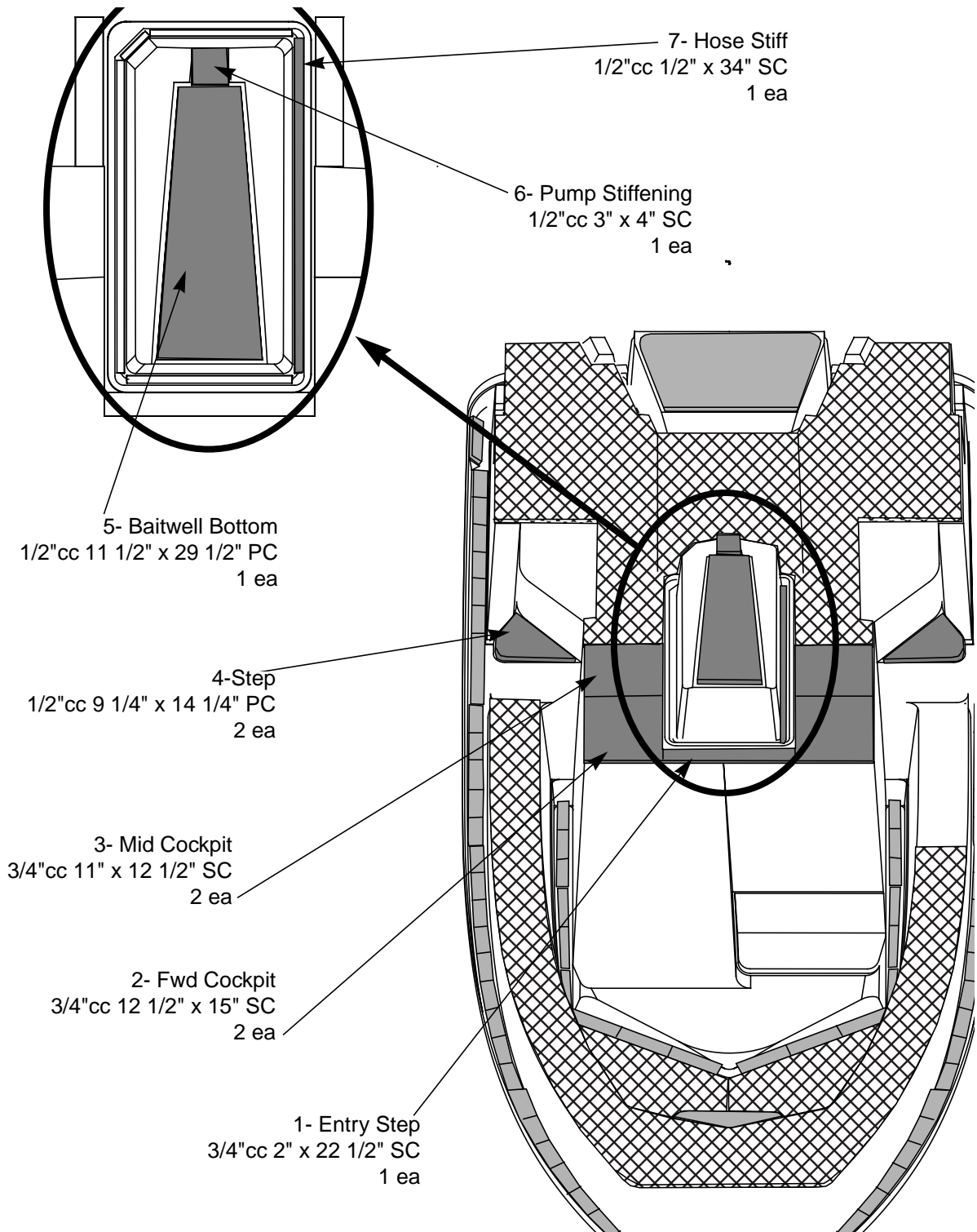

DECK STRUCTURE CONTINUED:

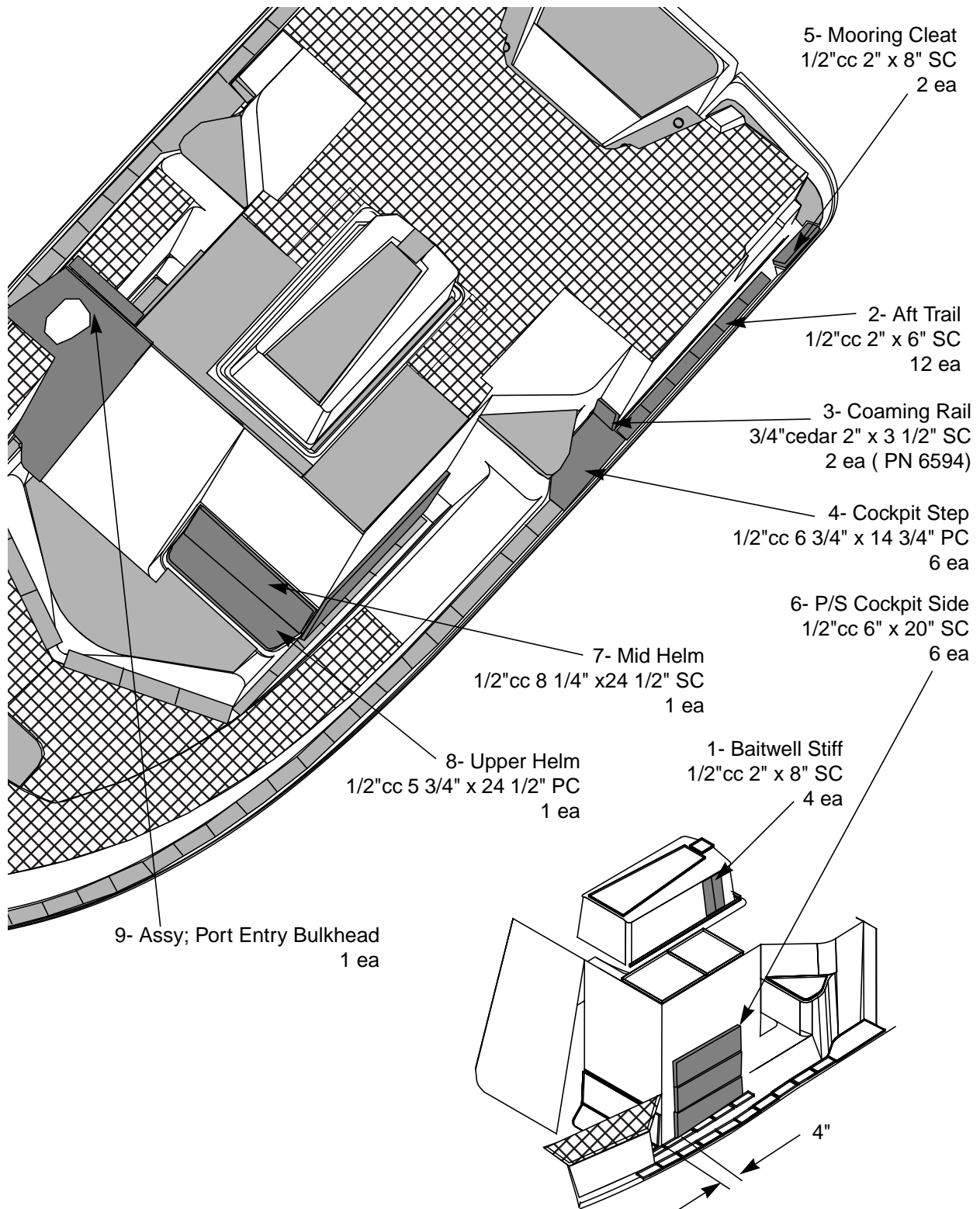

DECK STRUCTURE CONTINUED:

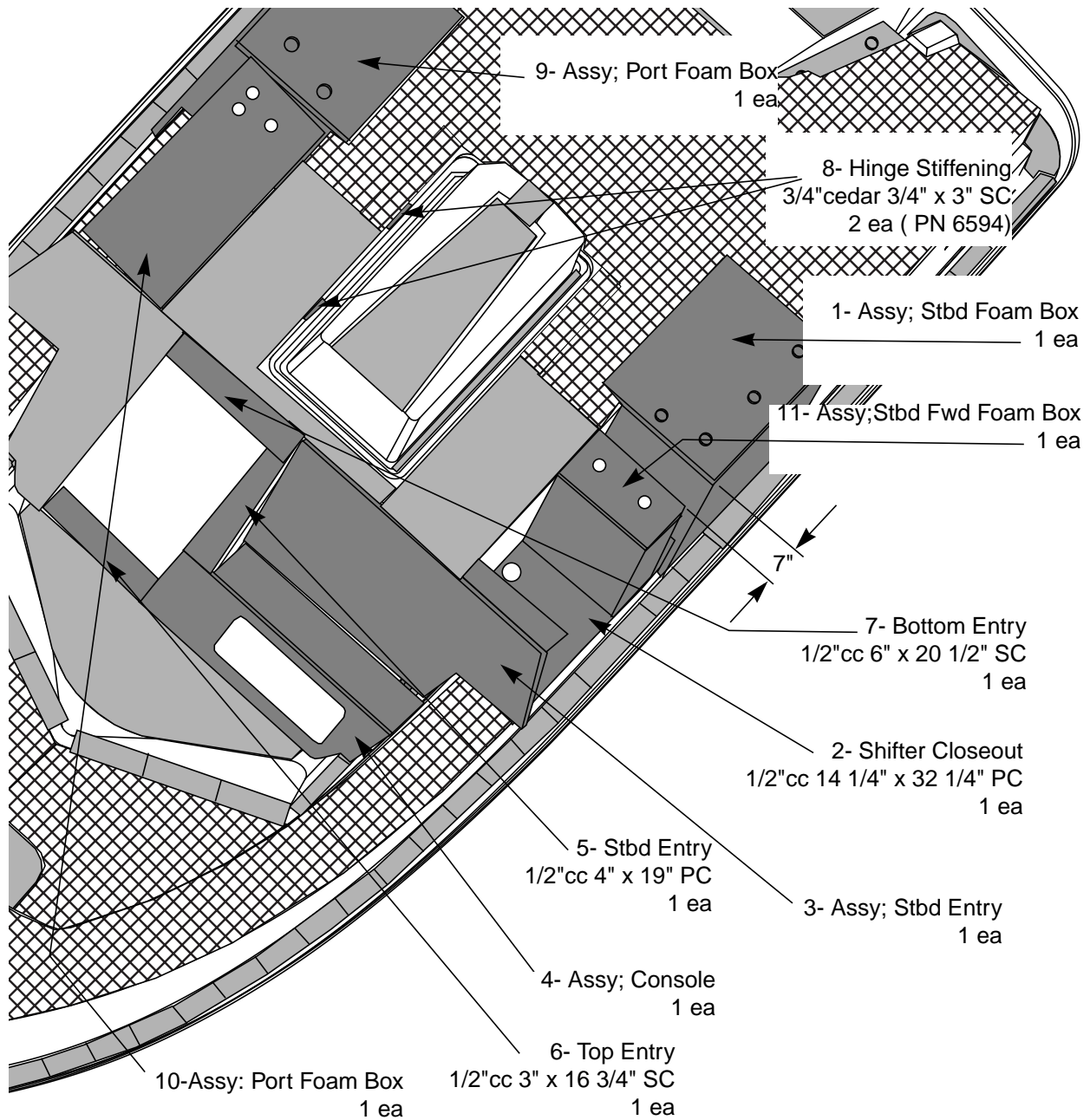

DECK STRUCTURE CONTINUED - DETAIL C:

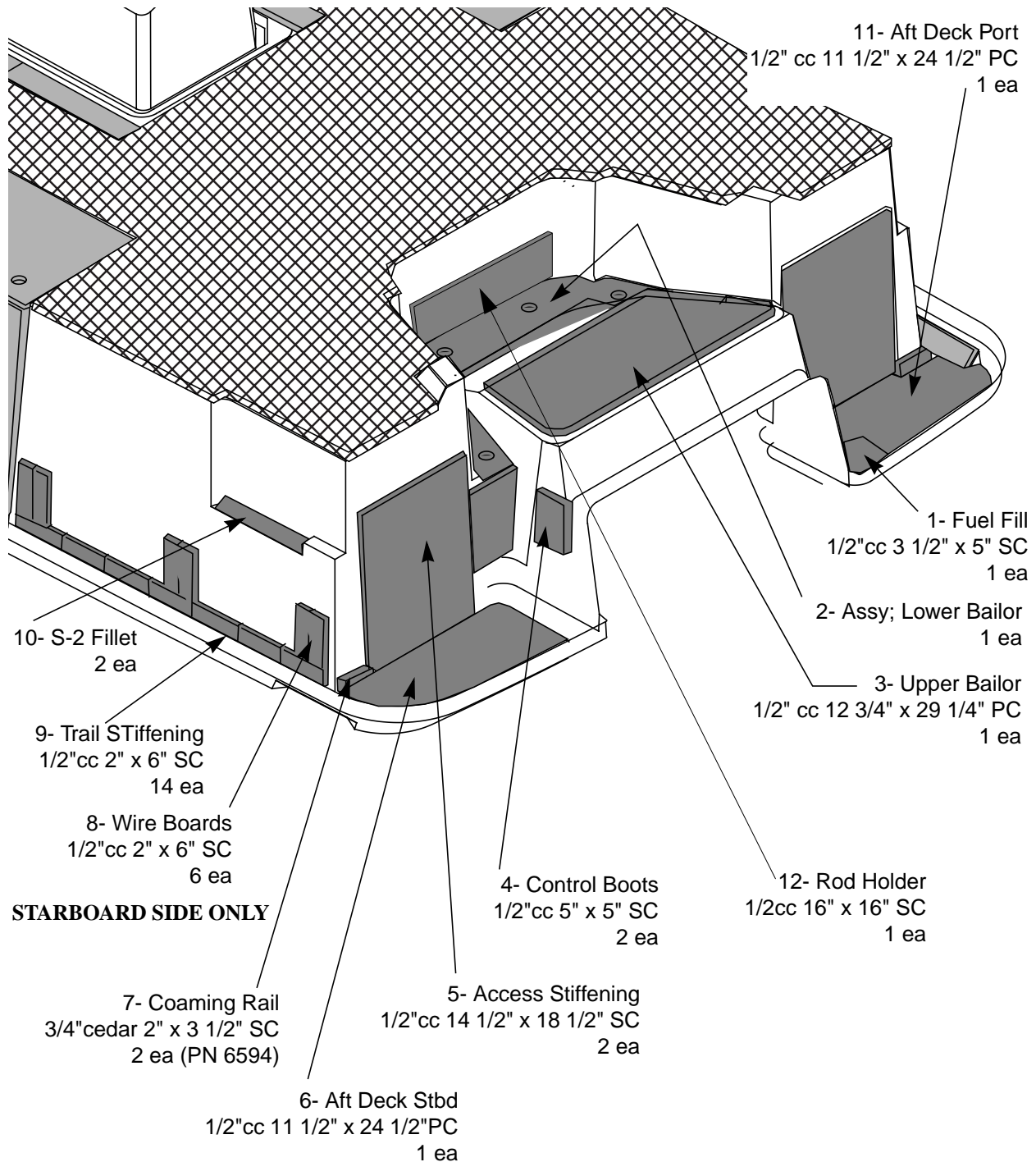

ROVING DETAIL:

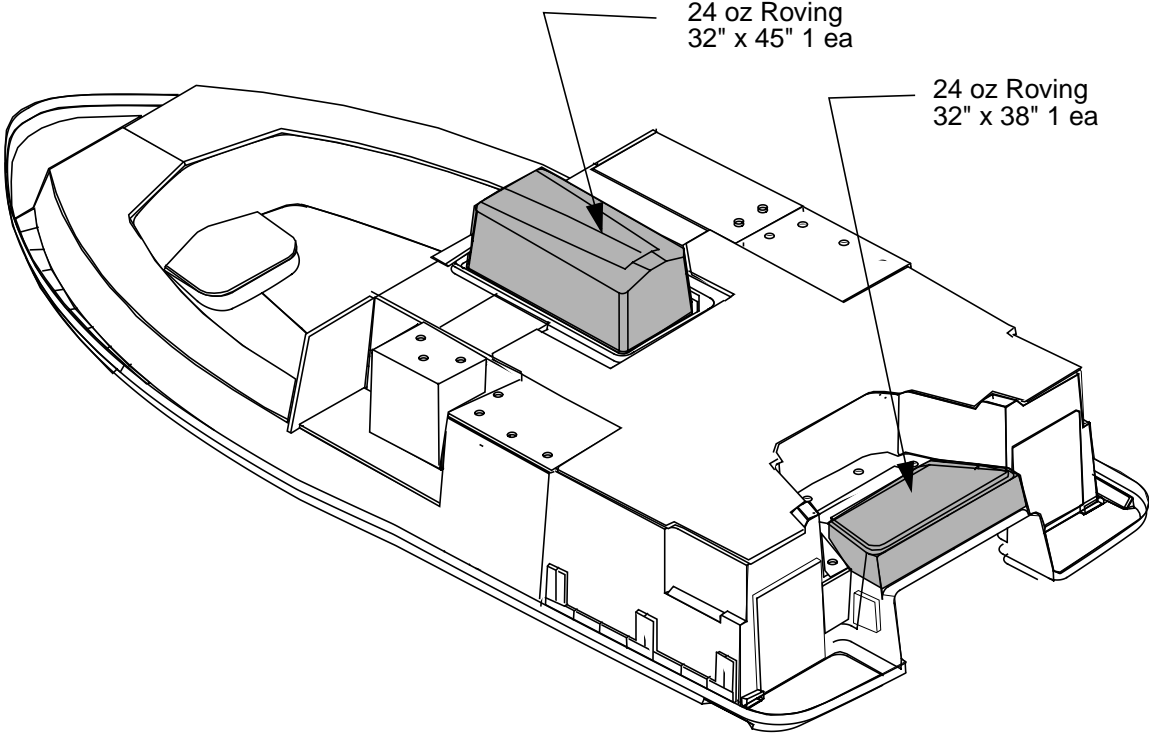
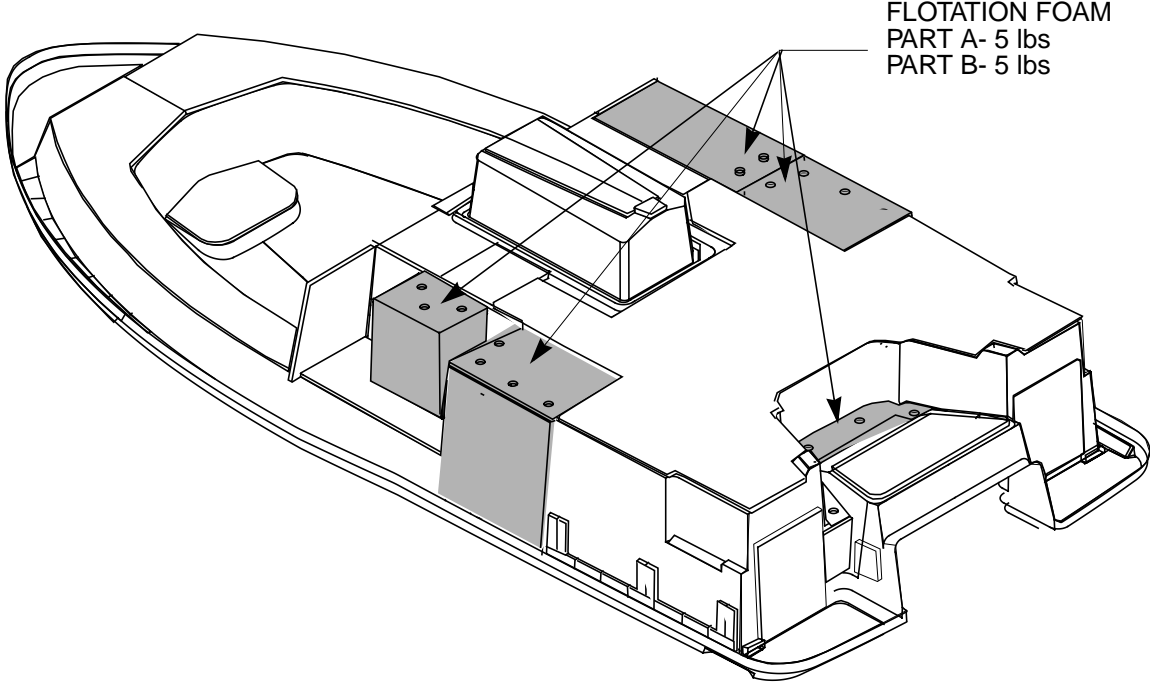

Figure 1

FLOATATION FOAM:



BASECOAT:

